



# Western Model A News

Official Newsletter of the  
MODEL A RESTORERS CLUB OF WESTERN AUSTRALIA, Inc

Year XXII Number II

SEPTEMBER, 2001

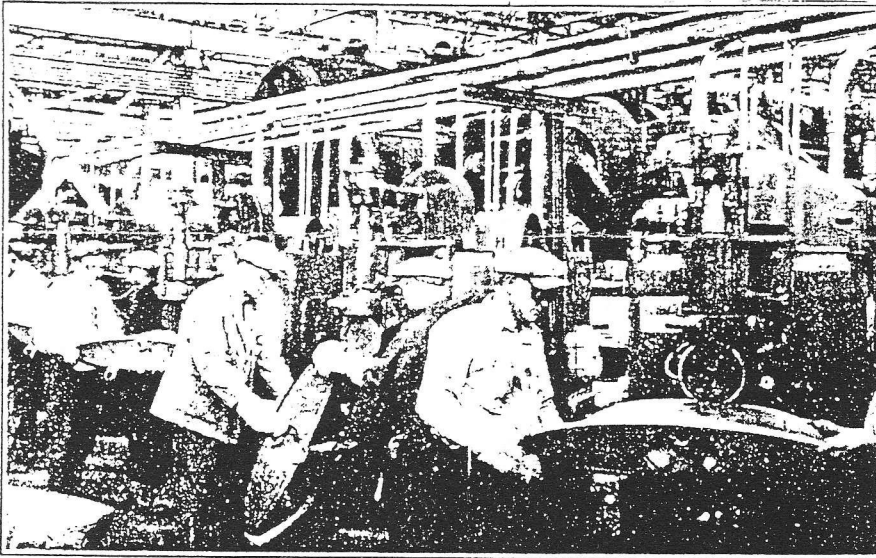

*Seam Welding the Model A  
Cowl Tank*

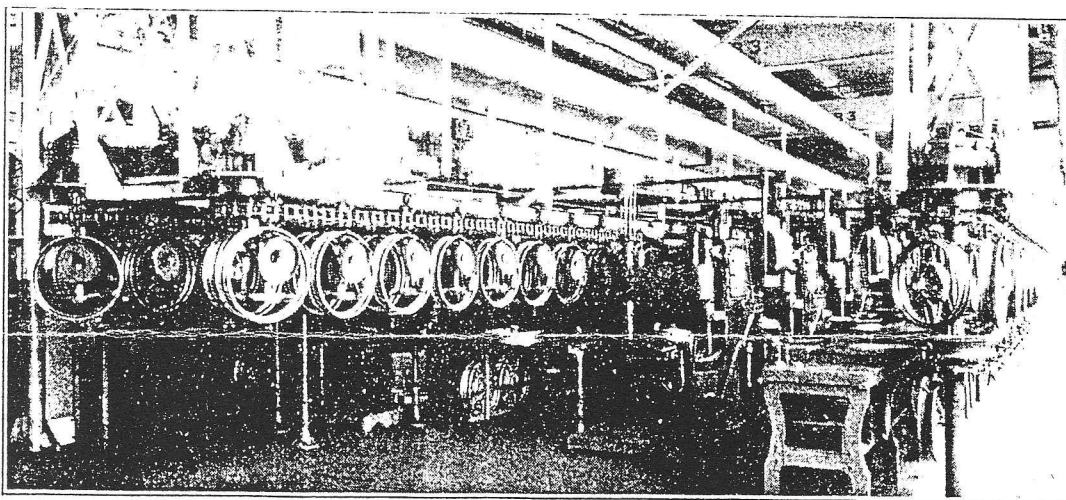

*Steel Wheel Welding Department, Hamilton Plant*

**Next Meeting/Run:** Saturday, 29<sup>th</sup> September  
Contact David for meeting time & place

This Club is the WESTERN MODEL A-s Chapter of the Model A Ford Club of America, Inc.  
MAFCA - 250 S. Cypress St., La Habra, California, 90631-5586, USA - Foreign Membership US\$34.00 per year

OFFICE BEARERS: *President:* PETER SARTORI ██████████ *Secretary/Treasurer:* TONI MAHONY ██████████  
*Vice-President:* RAY MAHONY ██████████ *Vehicle Examiner:* STEVE READ ██████████ *Editor:* LOUISE READ ██████████

**COPY DEADLINE:** By the first day of the month to ██████████ Thornlie, W.A., 6108

VIEWS EXPRESSED HEREIN ARE NOT NECESSARILY THOSE OF M.A.R.C. of W.A.

**SATURDAY, 29TH SEPTEMBER - MONDAY, 1ST OCTOBER, 2001**  
TOOWOOMBA SHAKEDOWN RUN

David Bussard organising - please contact him for details  
All members welcome

**SUNDAY, 7TH OCTOBER, 2001**

VINTAGE AUTO JUMBLE

Cannington Show Grounds from 7.00am  
Organised by VCC ph: [REDACTED]

**MONDAY, 15TH OCTOBER - 20TH OCTOBER, 2001**

WILDFLOWER RUN

John Laurie organising phone [REDACTED]

**SUNDAY, 28TH OCTOBER, 2001**

Meet at Banks Reserve, East Perth near the  
old gas works at 9.30am for 9.45 getaway.

Morning tea is provided. BYO lunch & BBQ packs  
as BBQs are available

Peter Gilberthorpe organising

**SUNDAY, 4TH NOVEMBER, 2001**

MOTOR MUSEUM RUN

**SATURDAY, 17TH & SUNDAY, 18TH NOVEMBER, 2001**

BENDIGO SWAP MEET

**SUNDAY, 18TH NOVEMBER, 2001**

Max Annear organising

**SUNDAY, 9TH DECEMBER, 2001**

CHRISTMAS LUNCH

Bridgeleigh Reception Centre, 198 Mary St, Wanneroo  
\$35.00 per person

Dora is collecting money now

SEE BACK PAGE OF NEWSLETTER

**EASTER 2002**

**17TH NATIONAL MODEL A MEET**  
**TOOWOOMBA, QLD**

Registration form & information available from  
Rally Secretary, MAFC of Qld,

[REDACTED] Carina Qld 4152



## **RAY ABBOTT ENGINE RECONDITIONING**

*\* Specialising in Veteran and Vintage engines*

*\* Cylinder Head Service \* Reboring and Sleaving \* Crankshaft Grinding*

*Recommended by MARC member*

Established 1973

18 RIO STREET, BAYSWATER

9272 4566

34 years Experience

MINUTES OF MARC (WA) INC  
HELD AT YORK ON SUNDAY, 26<sup>TH</sup> August, 2001

Meeting opened 1.50pm in the grounds of the museum.

Attendance and apologies: as per attendance book

The President welcomed visitors – Joy Osborne, Nancy Myers, Maurice McGregor, Darrell and Merle Tullitt, Rosemary Earle and Brendon Guy-Thornander. Brendon is a 16 year old who has a Model A under restoration. The President also thanked Don Sutherland for organising the day's activities.

Minutes: As per the club newsletter. Moved John Moorehead, seconded Jack Berkshire that they be accepted as read. Carried.

Business arising from Minutes: The club books have not yet been audited.

Financial Report: Income from leftovers from AGM sausage sizzle, Christmas Dinner deposits and subscriptions - \$110.00

Expenditure – subs to CCC, hire of hall and pits, bank fees - \$111.20.

Balances as at 1 <sup>st</sup> August – ANZ Term Deposit	\$11,480.66
Bank West	\$ 1,143.54
Cash in Hand	<u>\$ 361.30</u>
	\$12,985.50
Less U/P cheque paid	<u>25.00</u>
	\$12,960.00
Plus U/P cheques/rec.	<u>70.00</u>
TOTAL	<u>\$13,930.00</u>

Moved Pat Bussard, seconded Alan Smith financial report accepted as read. Carried.

Correspondence: In – SWVCC Inc. Classic Day 14<sup>th</sup> October, 2001; Leukaemia Week fundraiser 3-9 September; Wemyss vehicle auctions-Perth 8<sup>th</sup> December, Vauxhall Owners Club of Aust, WA – inviting us to run with them 9<sup>th</sup> September; Classic Adelaide Rally 18-21 October; Model A Ford Clubs of Aust – Delegates Meeting Minutes 2000 and proposals for 2001 meeting on 17 November, Kensington Primary School 75<sup>th</sup> Anniversary 27 October; Heart Kids WA; MAFC of SA office bearers; USA Model A scholarship; other advertising brochures.

Out – Cheque payment to CCC.

General Business:

2004 Rally progress: Ray gave an update on the development of the rally badge. David also gave a rundown on the USA contingent.

Peter Gilberthorpe: CCC – Need a club to run the 2003 Quiz Night. That club keeps the profits of the night – held at the Swan Districts Football Club.

Cars are also required by WAFL Grand Final – 32 open top cars on Friday 21 Sept to take players from the Esplanade to Forrest Place. Family pass to the Grand Final for participants. See Peter for details.

David Bussard – 2002 Run. David has organised a 'shake-down' and car checking run to Narrogin, Merredin and home. Participants in the 2002 Toowoomba event are encouraged to attend to give the vehicles a long run and hopefully iron out any problems that may arise. . This is on 29 Sept – 1 October. Anyone else may also come – please contact David immediately for details.

Bob Newton – Fundraising for Toowoomba – so far \$1474.00 in the kitty. There are other sausage sizzles which need people to run them on 22<sup>nd</sup> September, 20<sup>th</sup> and 27<sup>th</sup> October. These are to be held at Coles Inglewood and workers would need to be in attendance between 9.30am and up to 2.00pm. David and Pat indicated they may be able to do one. Anyone else, please see Bob or Alan Jeffree.

11<sup>th</sup> November Swap Meet – Fundraising committee requires goods and volunteers to man our site on this day.

October Goldfields Run - John Laurie advises that the dates he wrote on his mailout are incorrect.

The dates should be Monday 15<sup>th</sup> October onwards.

He also would like to obtain a steering wheel for a Model A.

Meeting closed 2.15pm.

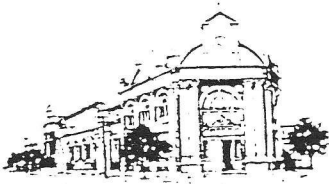

## YORK RUN 26<sup>th</sup> August, 2001

Club members assembled at Midland Gate, some at the East Gate others at the West, having sorted the problem Max finally got the members attention whistling them off in an orderly fashion.

The plan was to have morning tea at The Lakes roadhouse then to proceed to York, arriving at York at 11.30am.

The Model As assembled in single file in a parade through the town – horns tooting and much waving to our admirers. We were met by another three vehicles (Model As of course) making thirteen in all plus David's very nice coupe 1940 circa. The parade drove out of town a short distance to the York Historical Society building where they kindly made us welcome to park in the front of the building.

We all walked across the road and browsed through Leigh Carmichael's mini museum displaying a good collection of memorabilia.

The old York hospital, alleged to be haunted, is directly across the road where I was born, 10lbs 3oz in the old language.

We returned to the Historical Society building where we had our lunch and meeting on the front lawns. After the meeting a few of us departed for home, others stood and chin wagged.

The weather was beautiful and the drive home was very enjoyable.

*Don Sutherland*

---

## 2<sup>nd</sup> ANNUAL FATHER'S DAY RUN 2<sup>nd</sup> September, 2001

In spite of the appalling weather, Father's Day the 2<sup>nd</sup> of September 2001 saw a turn up of three Roadsters and two Phaetons and not forgetting the Bussard's coupe, which developed a headache and had to be replaced by their modern (a Ford at least).

We kicked off from the Riverton Forum and proceeded to Waroona via Mandurah and Pinjarra. Because it was Father's Day my son Josh and his girl friend Kareena decided it would be rather pleasant to ambush the group at the morning tea stop with a sausage sizzle. This gave us a pleasant interlude across the river from the Ravenswood pub.

On arrival in Waroona we were met by my fellow M.G.T.C. Owners club member John Bowles who helped organise a visit to Neil Twaddle's private stationary engine museum. An incredible collection with over eighty restored motors, three tractors, including a 1930s Ford, and other memorabilia. The collection only started a little over five years ago and has reached such a size that Neil has had to buy the block next door to build the present facility.

After everyone had viewed the collection we then retired to Centennial Park next to the old Waroona school for lunch and we were joined by Toni Mahony (Ray having snuck off to Christmas Island on some excuse!)

Those present were Chris, Nick & Mike Butler, Max & Dora Annear, John & Shirley Hall, Lindsay Blacklock, John & Helen Moorehead (chauffeured by son David), David & Pat Bussard and Toni Mahony in their moderns. All in all excluding the weather it was a great day.

*Chris Butler*

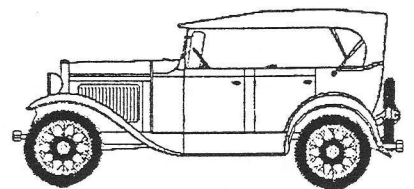
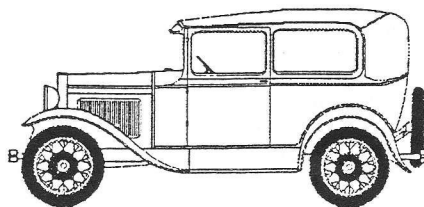
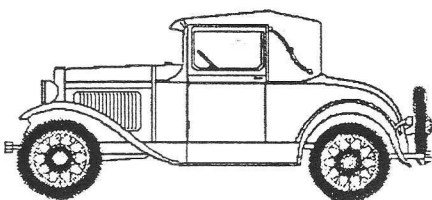

## CHECKING CLEARANCE BETWEEN VALVES AND PUSH RODS

To insure a uniform power stroke in each cylinder, it is absolutely necessary that the correct clearance (.010 to .013 in.) be maintained between valves and push rods, and that the clearance be checked *with the push rod resting on the heel of the cam* (the lowest point of the cam).

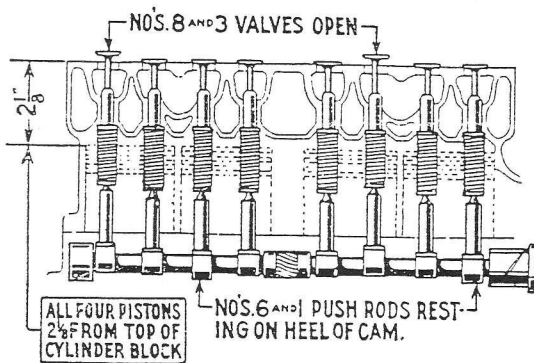

Fig. 37

When checking this clearance, an easy way to determine that the push rods are on the heel of their respective cams is to first turn the engine over until numbers 8 and 3 valves are fully opened. At this point, all four pistons will be  $2\frac{1}{8}$  in. from the top of the cylinder (see Fig. 37) and numbers

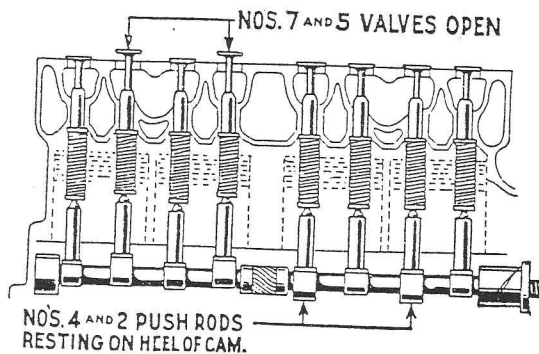

Fig. 38

6 and 1 push rods will be resting squarely on the heel of their respective cams and the clearance can be easily checked.

After adjusting the clearance between numbers 6 and 1 valves and push rods, turn the engine over exactly one-half turn. Numbers 7 and 5 valves

will now be open, and numbers 4 and 2 push rods will be resting on the heel of their cams. (See Fig. 38.)

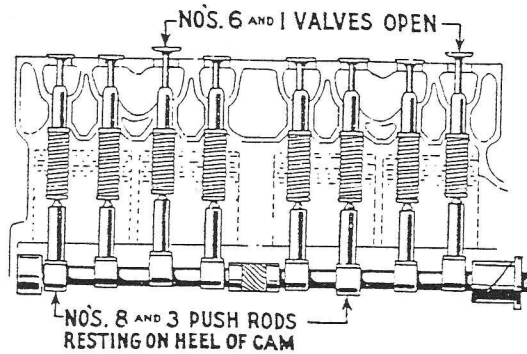

Fig. 39

After adjusting the clearance between numbers 4 and 2 valves and push rods, again turn the engine over exactly one-half turn. Numbers 6 and 1 valves will now be open, and numbers 8 and 3 push rods will be resting on the heel of their respective cams. (See Fig. 39.)

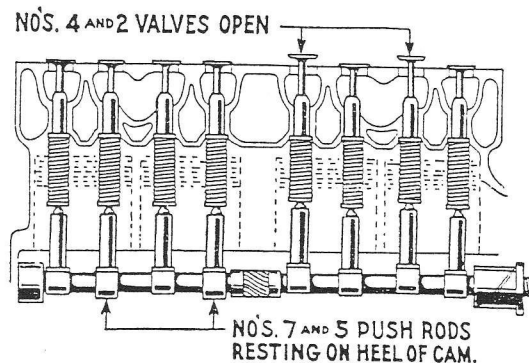

Fig. 40

After checking the clearance between numbers 8 and 3 valves and push rods, once more turn the engine over one-half turn. Numbers 4 and 2 valves will now be open, and numbers 7 and 5 push rods will be resting on the heel of their cams and their clearance can be checked. (See Fig. 40.)

## HUBS

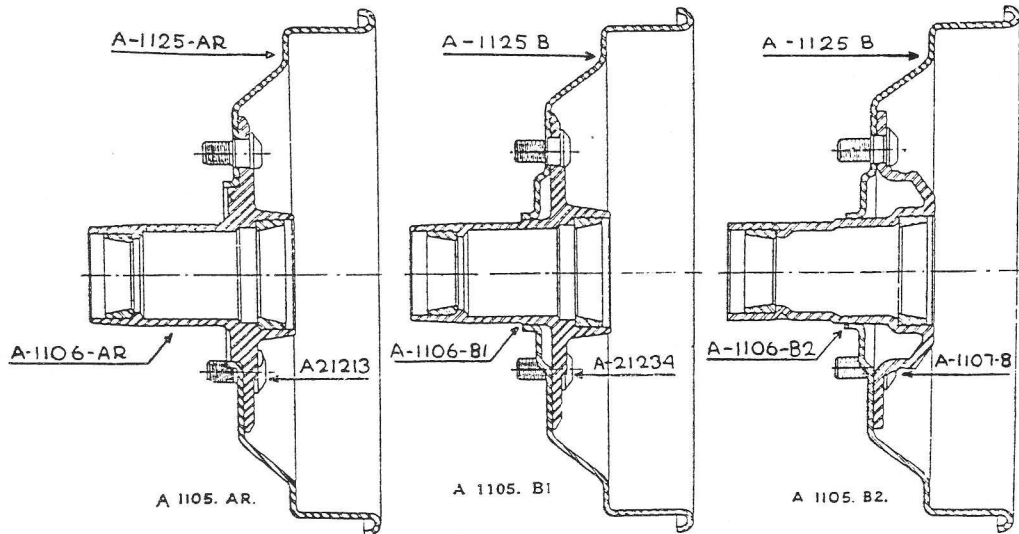

Fig. 41

### FRONT HUBS

Three different types of front wheel hubs have been used on the Model A chassis and these are illustrated above (Fig. 41). A-1105-AR is the hub which was used on cars not equipped with the new style emergency brake, and is now supplied for service requirements only.

A-1105-B1 is the hub that was used on the earlier models equipped with the new style emergency brake, and is now replaced by A-1105-B2. It will be observed from the sketches that the latest type

hub is considerably larger round the inner roller bearing race than the earlier type, and for this reason it is necessary to use a slightly different type of front brake grease baffle assembly with these two hubs. The baffle used with the A-1105-AR and A-1105-B1 type hubs is interchangeable with that used on the truck and is now carried under the part number AA-2059. The baffle for the A-1105-B2 hub is carried under the part number A-2060-B.

Mechanics should take care that the correct type of baffle is used when replacing either hub or baffle.

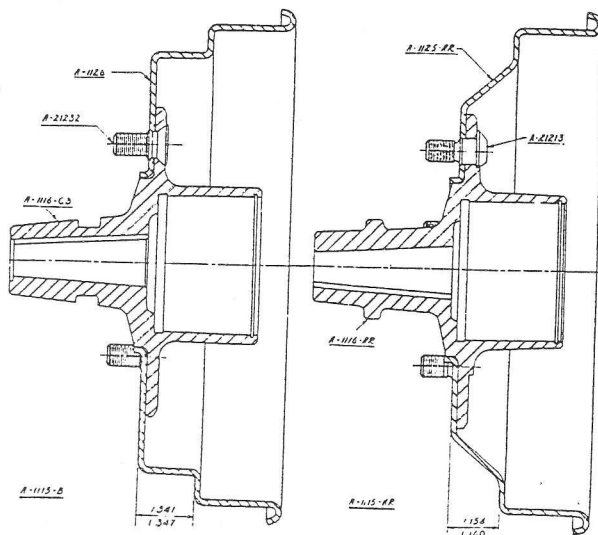

Fig. 42

### REAR HUBS

The sketch shows the two types of rear hubs in use. The A-1115-AR hub and brake drum was designed for use with the A-1015-AR wheel and was used up to August 1928.

The A-1115-B hub and brake drum was designed for the new A-1015-B wheel, having the specially shaped rim to take the emergency brake shoes and brought into use after August 1928.

Reference to Service Bulletin for August 1929 will show that AR wheels cannot be used on the B hubs and vice versa.

Hi everyone!

Has sure been a busy summer for us 'tween the All Model A Swap Meet, NW Regional Meet in Postfalls, ID, Mystery Tour with the Gertie Club AND the Mystery Tour with Evergreen this weekend!!

Thankfully, Robert got the engine/overdrive installed in time for the Gerties Tour (drove the Mustang to the NWR Meet) and has made the necessary adjustments for us to go with the Evergreen Club Sat. Think the Woody will be retired to the garage after this wkend come out again next Spring.

Robert & Steve Hamilton have made plans to attend the Hershey SwapMeet in October and are looking forward to DAYS of walking and possibly finding some treasurers. Judy & I are going to "hold down the fort" and let them go solo.

While they're gone I'm going to have my sister come down and walk me thru some puter stuff so I can get outta the slow lane of this super info hwy.

Have done something to my machine which won't allow me to open up zip files so have been sending them to myself @ work and opening them there....labor intensive!

Might even figure out my digital camera a bit better. As it is, I tried to use my SmartCard this week and it turned DUMB on me...needs new batteries!--only took me an HOUR to figure THAT one out!

How are plans coming along for attending the 2002 Meet in Toowomba???

We're sure looking forward to it! Are you working on a Club Hubble?? We had 65 entered at the Regional in Postfalls...that's a record for local meets!

Can't tell you how much I look forward to receiving your newsletter and catching up on happenings over there.

Think Summer's just about come to an end here...you can feel the "nip" in the air in the evenings and leaves have begun to turn color. It's my favorite time of the year. Wasn't until we'd begun to travel to Hershey, PA in the fall that I even noticed the amount of trees that we have around here with color!

Guess that's about all from here for now...Tell everyone HI for us!!

Regards,  
Christy & Robert McLaughlin



### POTATO QUICHE

#### INGREDIENTS

4 Potatoes, thinly sliced  
2 cups chopped mixed vegetables  
2 leeks, thinly sliced  
6 eggs lightly beaten  
½ cup low-fat milk  
Freshly ground black pepper  
1 tablespoon parmesan cheese  
1 tablespoon freshly chopped parsley

#### METHOD

Arrange potato slices in a 25cm quiche dish. Cook on high in the microwave for 5-6 minutes. Cook leek and vegetables and spread over potato. Beat eggs with milk and pepper. Pour over vegetables. Sprinkle with parmesan cheese and parsley. Bake at 180C for 45 – 50 minutes or until set and lightly browned. Serve with fresh bread.

I use half potato and half orange sweet potato, and a dash of Worcestershire sauce.

HELEN MOOREHEAD.



17<sup>th</sup> NATIONAL MODEL "A" FORD  
MEET TOOWOOMBA 2002,  
QUEENSLAND



RALLY UPDATE NO. 3 – AUGUST, 2001

Thanks to everyone who has paid their registration. It really helps to have the cash on hand to pay the accounts. We have 220 registrations and, of these, 153 have paid.

URGENT: In some cases we only have your early bird registration form which gives your name and address. If you intend to come to the 2002 National Meet, would you please fill out the full registration form and return it as soon as possible so that all details of passengers etc can be included on the computer. This information is important for us in the planning and catering of the National Meet.

Our Club's main aim when planning this National Meet is to keep the cost to entrants as low as possible and have a relaxed and friendly rally. To make the most of our time together, we intend to start the rally programme on Thursday commencing with registration from 1.00pm and the trade tables with items for sale. We have changed the traditional nibble and natter to a casual barbecue and wine tasting followed by an official welcome to all visitors and a brief outline of Friday's events.

I hope that everyone is busy building and racing their Hubley cars. I have heard that there is an original 1930 Hubley being built in USA by A.B. of the Victorian Club. Our track is three lanes wide, 40ft long and has a 5ft drop with electrical timing to keep the action going.

For those people without a vehicle, in motels, we have a 25 seater bus available as well as a discount deal with Avis if you need to hire a car.

As Easter is early in 2002, our merchandise orders have to be placed before Christmas so that it will be available for the Meet. I will be sending the meal and merchandise form out in September so that it can be returned by November.

DON'T FORGET: Please fill out your FULL registration form.

See you at Bendigo. Regards, Rod McMullin.

Rally Co-ordinator

Rod McMullin

Ph: [REDACTED]

Fax: [REDACTED]

Rally Secretary

Ron Johnman

Ph: [REDACTED]

Fax: [REDACTED]

MODEL "A" FORD CLUB of QLD inc  
[REDACTED]  
CARINDALE 4152  
BRISBANE, QLD



# Notebook

**BIRTHDAYS for September: Birthstone: Sapphire; Flower: Aster**

Jill Axford, Barry Bristow-Stagg, Gail Duns, Barry Fowler, Joy Fowler, Georgina Hart, Germaine Jeffree, Beth Martin, Graham McDonald, Peter Sartori, Margaret Strahan, Don Sutherland, John Teale, Malcolm Wood & Chris Wringe. Happy birthday!

**NEW MEMBERS:** Please welcome John & Gayle Easterbrook, [REDACTED]

Bentley. Ph: [REDACTED] These folk have a restored '28 Coupe. Add them to your members register. An interesting snippet of information, it seems that John's Coupe, out of Canberra via Queensland ex Argentina, was made in the same factory as Steve Read's Factory Pickup, Twin Cities in Minnesota, USA. It is hard to believe after all the years and miles that they both finish up in Perth.

**CHANGE OF ADDRESS:** Frank Farrelly has moved to [REDACTED] Tuart Hill,

Ph: [REDACTED] Please alter your register.

**WANTED:** Model A steering wheel. John Laurie Ph: [REDACTED]

**FOR SALE:**

1928 Phaeton restored on concessional license. Price \$17000 - \$18000 neg.  
Photos & relevant history with car  
Contact John Pitts Phone/Fax [REDACTED]

**NATIONAL REGISTER:** Available now or alternatively at Bendigo Delegates Meeting. Approximate cost will be \$4.50.

**E-MAIL:** It is always great to hear news from our club members and especially those who are overseas, so I have included the latest from Christy & Robert in this newsletter. It makes interesting reading, never a dull moment from all accounts!

**AN EDITORIAL WHINGE:** Sorry I'll make it short. PLEASE PLEASE PLEASE if you organised the run, would you do the write-up before I have to get on the phone and badger you about it. Thanks.

**NOT SO WELL LIST:** Couple of members on the list, hope they are feeling better. Best wishes to Don Sutherland and also Dora Annear who recently had an eye op.

**VOLUNTEERS:** As mentioned in the minutes, sausage sizzles have been organised to raise funds for those going to Toowoomba next year. They have been a great success but to continue in that vein, we need people to man the barbies. If you intend to attend the National please support the cause and volunteer some time. Bonus -low cost lunch!

**DOES ANYONE OWN A CAMERA?** if you do would you be so kind to take some photos on the outings and donate them to the club album.

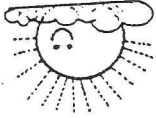

If undelivered, please return to:  
Thornlie [redacted]  
Western Australia, 6108

SARTORI Peter & Lorraine  
[redacted]  
MURDOCH WA 6150

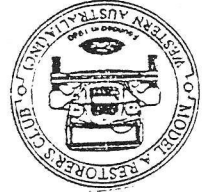

# WESTERN MODEL A NEWS

## EXTRA EXTRA READ ALL ABOUT IT!

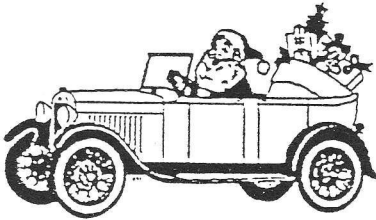

I'm  
talking  
about  
Christmas  
Lunch,  
9 Dec 2001.

There are only eight  
weeks left for me  
before I have to give  
tentative numbers for our  
Christmas Celebration.

Therefore I am asking for those  
members who know they will be  
coming to please send me their money  
(\$35 per person), or at least contact me  
on [redacted] postal address [redacted]  
[redacted] Hillarys, 6025.

***Dora Annear***

Our country members  
are always very  
welcome so  
don't be shy!

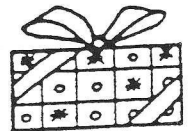

Secretary/Treasurer: Toni Mahony, [redacted] Bedford WA 6052  
Ph: [redacted]