



Western Model A News

Official Newsletter of the
MODEL A RESTORERS CLUB OF WESTERN AUSTRALIA, Inc

Year XIX Number I

AUGUST, 1998



HEY MOM... THERE'S THE HOUSE
DAD WANTS TO BUY.

Next Run/Meeting: Sunday, 30th August. Meet: Causeway Carpark. Time: 9:15am

This Club is the WESTERN MODEL A-s Chapter of the Model A Ford Club of America, Inc.
MAFCA - 250 S. Cypress St., La Habra, California, 90631-5586. USA - Foreign Membership US\$34.00 per year

OFFICE BEARERS: *President:* DAVID BUSSARD [REDACTED] *Secretary/Treasurer:* PAT BUSSARD [REDACTED]
Vice-President: PETER SARTOR [REDACTED] *Vehicle Examiner:* STEVE READ [REDACTED] *Editor:* LOUISE READ [REDACTED]

COPY DEADLINE: By the first day of the month to [REDACTED] Thornlie, W.A., 6108

VIEWES EXPRESSED HEREIN ARE NOT NECESSARILY THOSE OF M.A.R.C. OF W.A.

SUNDAY, 23RD AUGUST, 1998
HOGAN'S RUN RALLY FOR CHARITY
Organised by Triumph Sports Owners Assoc.
Start: Garden City Car Park, Risely St, Booragoon.
Time: 10:00 am - 11:00 am
Cost : \$20 per car plus gourmet donation
For further details phone [REDACTED]

SUNDAY, 30TH AUGUST, 1998
Meet at Causeway Carpark 9:15am for a 9:30 departure
Organised by John & Pat Laurie

SUNDAY, 20TH SEPTEMBER, 1998
The run to Wongan Hills has been cancelled, however,
Alan & June Smith have planned a run to visit Rex & Chris Downey's
property at Katrine, which is between Northam and Toodyay.
The Downeys have a great collection of memorabilia and cars,
including a Ford A, Minerva, Overland, etc.
One of the buildings dates back to 1832, making it one of the oldest in the state.
The Downey's daughter is an artist and has a gallery on the property.
There is a gate charge of \$5 per person, children free,
which allows us to visit the museum and art gallery.
Meet at Midland Gate 8:30am for a 9:15am departure.
Lunch and meeting at Downeys.



OCTOBER, 1998
Darren & Germaine Jeffree to organise . 25

SUNDAY, 11TH OCTOBER, 1998
AUTO JUMBLE
Organised by the Veteran Car Club

NOVEMBER, 1998 3rd Sunday
Max & Dora Annear to organise ~~22~~ Nov ~~22~~
22

SUNDAY, 22ND NOVEMBER, 1998
MANDURAH CAR SHOW
Hosted by the Ace Ford Club - proceeds to the Variety Club of WA
Venue: Mandurah Greyhounds Track, Gordon Rd, Mandurah
Show Date: Sunday, 22nd Nov, 10:00am to 4:00pm
Set up time: Saturday, 21st Nov, 10:00am to 5:00pm (security available)
Entry Fee: nil, prior to entry closing date (6th Nov)
Food & drink available at the grounds

SUNDAY, 6TH DECEMBER, 1998
CHRISTMAS LUNCH - 12:30pm
will be held at the Peppermill Restaurant in Gidgegannup
The restaurant is situated in the main street and there is plenty of parking
The meal consists of three courses and it is BYO.
Cost is a mere \$22.50 per person so make it a date

**MINUTES OF MODEL A RESTORERS CLUB OF WA (INC.)
ANNUAL GENERAL MEETING**

Held at 39 Sovereign Dr, Thornlie on Sunday, 26 July, 1998

Meeting opened at 2:10 pm. Steve Read in the chair.

Attendance & Apologies: As per attendance book.

Minutes of 1997 AGM: Read and accepted. Moved correct P. Sartori, sec'd P. Gilberthorpe.

Business arising: Fees to remain as 1997. Some members remitting incorrect subs. 1995 subs were for 18 months. Not required this year.

Correspondence In: Correspondence for AGM & General meeting was tabled. MAFCA re: *The Restorer* magazine, board decision to airmail to overseas chapters; several e-mail regarding back copies; delegates meeting minutes from MARC Canberra for discussion at Bendigo; Spring in the Valley news; Avondale Discovery Farm; Infolink from Library of WA; Sock it to You Fund-raising; ACE Cinema fund-raising; MAFCA Board Meeting Minutes & Chapter newsletter; Eileen Hogan Memorial run; Penrite. Moved Jack Berkshire, sec'd John Timmings.

Correspondence Out: Nil.

Financial report: As per audited balance sheet. Accepted as correct by P. Sartori, sec'd R. Blewett.

President's Report: to be published in newsletter.

Election of Officers: All positions were declared open, the following people were elected for 12 months.

President: nominations received for John Timmings & David Bussard, David Bussard ~~elected~~

Vice-President: Peter Sartori

Secretary/Treasurer: Pat Bussard

Editor/Sales: Louise Read

Events co-ordinator: Steve Read

Vehicle Examiner: Steve Read, with assistance from Max Annear & Reg Blewett. Both Max & Reg to supply information for Dept of Transport to become authorised examiners.

Rally Marshal: Max Annear

CCC Delegate: Peter Gilberthorpe. John Hall advised he also attends meetings.

Property Officer: Darren Jeffree

Librarian: Steve Read

Committee members: Alan Smith & John Moorehead

~~Terms will be for two years at next year's elections.~~

General Business: Visitors on the Around Australia run were met and assisted by several club members during the week they were here. On the Sunday before their departure a bus trip around the city was organised. Several club members joined the travellers on the tour.

John Timmings spoke about the poor attendance from WA at the National Meet. More members encouraged to attend Wodonga in 2000. A sub committee to be formed to co-ordinate plans for a larger contingent of WA attendees. P. Sartori, J. Timmings, S. Read, D. Jeffree & J. Hall volunteered for this task.

Meeting closed: 2:55 pm.

**MINUTES OF MODEL A RESTORERS CLUB OF WA (INC.)
GENERAL MEETING**

Held at 39 Sovereign Drive, Thornlie, Sunday, 26th July, 1998

Meeting opened at 2:55 pm. Steve Read in the chair.

Attendance & apologies: as per attendance register.

Previous minutes: as per newsletter. Moved J. Timmings as correct. Seconded P. Sartori.

Business Arising: Christmas in July evening on July 11 was a good night and good value. J. Berkshire thanked Dora Annear for her effort, commenting that she does a marvellous job organising social events for the club. All agreed.

Correspondence In & Out: As per AGM.

General Business:

Christmas function - Pat Laurie offered to have a Christmas lunch at her home, but has discovered a good restaurant in Gidgegannup at \$22.50 (byo). Dora Annear suggested the Tawarri Lodge smorgasbord at \$25, buy own drinks. P. Laurie's suggested was voted as the choice. Date Sunday, 6th December.

Dora advised that John Laurie was very ill, Pat Bussard to send a get well card from the club.

Next run 20th September organised by A & J Smith, visiting a house & museum half-way between Northam & Toodyay. Meet at Midland Gate carpark. \$5 entry for the house & \$5 for the museum. No Wildflower Run this year.

Financial report: As per AGM.

Accounts for payment: Bus Hire- moved F. Farrelly, sec'd P. Sartori that S. Read be reimbursed. Food for Sausage sizzle, postage & paper. Gift of \$100 to be sent to Andres Tuvik for auditing the books- moved G. Jeffree, sec'd R. Blewett that these be paid.

Reno Meet - D. Bussard gave brief positive report of the Meet he and Pat attended. David has a variety of technical info.

Good Luck/Bad Luck Trophy: was awarded to Max Annear. Max & Dora started out on the Manifold cooking run and only got a short distance when a valve guide broke causing considerable damage plus stripping a timing gear. They changed to a modern car but forgot to take lunch off the manifold.

Manifold trays: Darren has four trays available.

Future runs: G & D Jeffree to organise October, M & D Annear to organise November.

CCC: P. Gilberthorpe expressed a desire to see a better turnout for Car Show in March, including a theme for the display. Whiteman Park has a new curator. Quiz night 29/7/98.

Vehicle examinations: S. Read was pleased to report that except for a few very minor things, vehicles examined were in a good and safe shape.

Awning: It was decided at a previous meeting to hire awnings, if needed, to reduce storage problems.

VCC rooms: S. Hall advised cost of hiring VCC room is \$30, but if involved with VCC cost is only \$10. D Bussard mentioned that vehicle examination facilities are available at a reasonable cost.

1999 AGM: Next year's AGM and Vehicle examinations might be held on different days.

Ford Parts: A. Jeffree has details of a provider of Model A and V8 parts in Los Angeles.

Thanks: J. Berkshire thanked the Vehicle Examiners for a job well done. S. Read thanked everyone for their attendance.

Meeting closed: 3:40 pm

MODEL A RESTORERS' CLUB AUSTRALIA (W.A BRANCH) INC.

	1997		1998
\$	- BALANCE BROUGHT FORWARD AS AT 30th JUNE 1997		\$ 1,191.22
	<u>INCOME</u>		
\$	1,465.00 SUBSCRIPTIONS	\$	1,530.00
\$	1,155.00 DINNERS	\$	1,316.00
\$	45.00 BADGES	\$	45.00
\$	54.00 T SHIRTS	\$	54.00
\$	409.40 RAFFLES	\$	392.35
\$	35.00 VINTAGE PLATES		
\$	753.37 BANK INTEREST	\$	579.48
	REFUND	\$	150.00
\$	25.00 NEWSLETTER ADVERTISING	\$	75.00
\$	37.10 MISCELLANEOUS	\$	17.00
\$	<u>3,978.87</u>		<u>\$4,158.83</u>
	TOTAL INCOME FOR THE YEAR		
	<u>LESS EXPENDITURE</u>		
\$	1,235.74 DINNERS		
\$	52.25 STATIONERY & RAFFLE TICKETS	\$	193.75
\$	39.05 BADGES	\$	99.00
\$	498.15 POSTAGE	\$	467.35
\$	506.00 PHOTOCOPIER PURCHASE ,COPYING ,REPAIRS	\$	457.37
	T SHIRTS	\$	165.11
\$	62.11 BANK FEE'S	\$	66.48
\$	35.00 C.C.C	\$	35.00
\$	- INSPECTION FEES	\$	52.00
\$	149.00 INSURANCE		
\$	60.35 DEPOSITS (XMAS & TUNNEL)	\$	331.00
	DONATIONS	\$	1,065.00
\$	150.00 HONORARIUM	\$	-
\$	<u>2,787.65</u>		<u>\$ 2,932.06</u>
	TOTAL EXPENDITURE FOR THE YEAR		
<u>\$</u>	<u>1,191.22</u>	SURPLUS(DEFICIENCY) OF INCOME OVER EXPENDITURE	<u>\$ 1,226.77</u>
	FOR THE YEAR		
	BALANCE OF BANK ACCOUNTS PLUS PETTY CASH ON		
<u>\$</u>	<u>12,394.39</u>	HAND	<u>\$ 13,622.16</u>

I have examined the Books of Account and supporting records of the MODEL A RESTORERS' CLUB AUSTRALIA(WESTERN AUSTRALIA BRANCH) INC for the twelve months ended 30th June 1998. In my opinion the attached Statement of Income and Expenditure reflects a true and fair view of the state of affairs of the Club for the year ended on that date.



 Andres Tuvik
 Accountant
 24 July, 1998

PRESIDENT'S REPORT 1998

Well it seems as though it was only yesterday we had our last Annual General Meeting. The years fly by and yet they seem to be full of things happening.

Our club has retained its reputation of being a top club with a 100% rejoining of members and after all it is the members that make the club.

We have enjoyed many and varied runs this year, including visits to Heytsbury Museum, the Bunkers at Mosmans, trips to Cunderdin, Whitby Falls and our Wildflower and Poker Runs were also enjoyed.

Our club was represented at the National Meet in Canberra along with all other states including Tasmania and this shows that the Model A movement is still strong.

It is the 70th Anniversary of the Model A Ford in Australia and we celebrated this occasion with a Christmas in July Dinner.

The club grew this year with the addition of several new members and some more restored cars appearing, as well as some older restorations acquiring new owners. Even members who sold their cars have elected to remain in our club as friends, which proves that the cars are not the only draw card.

The most satisfying thing for me is that hardly a day passes without a new member enquiry or another A surfacing. Will they ever stop? I hope not.

Finally I encourage any one that can, to endeavour to attend the National Meet in Wodonga in 2000 as we have been lucky to obtain the 2004 Rally in Perth and should foster as much goodwill as possible.

Yours in A-ing

Steve Read



70th ANNIVERSARY OF MODEL As IN AUSTRALIA CHRISTMAS IN JULY

To celebrate 70 Years of the Model A Ford, forty four members and friends of our Club had a night out at the Dorchester Function Centre, 38 Rome Road, Melville, on Saturday the 11th July, 1998.

The evening was in the form of "Christmas in July" comprising a very nice meal as well as unlimited drinks (beer, wine and soft drinks) served at our tables, followed by a most entertaining Variety Show, at the conclusion of which there was dancing for about an hour to round off the night. Music was provided during the meal by a drummer and pianist. This was just delightful and thoroughly enjoyed by everyone.

Several members came dressed in clothes of the era, which was very nice to see.

Thanks to Ron Andrews and Leslie Lloyd (especially Leslie) for making a Commemorative Placard for the occasion. This was placed in front of the stage for all to see 'what we were about'. Most acceptable. Although we shared the venue with other people, the atmosphere was very relaxed and we mingled amongst ourselves hearing about Edith and Alan Jeffree's holiday; catching up with Dorothy and Bill Bennie and chatting to country members Rosalie and Gary Eva (Brookton), Lesley and Alex Polley (Manjimup) and Sylvia and Barry Bristow-Stagg (Northam). We were all very pleased to have some country members join us for the evening.

Our Chapter is a long way from Henry Ford's home town and 70 years have gone by since the Model A Ford vehicle, as we know it, was produced in America, but I'm sure if he was alive today, Henry would have to feel very happy and proud at the number of Model As still in existence world wide and the pleasure and comradeship it has given to members of the Fraternity.

Max and I thoroughly enjoyed the 70th Anniversary Celebration and sincerely hope everyone who attended did likewise.

Dora Annear

Restoring the Model A Ford Speedometers

Courtesy of the Beaver Chapter, MAFCA, Portland, Oregon.
Article and sketches by Gordon Fletcher.

PART SIX

DECALS

Mark the wheels or make tool #4 before removing the old numbers from the wheels with lacquer thinner. **WARNING: SOME REPLACEMENT WHEELS ARE MADE OF PLASTIC, DO NOT USE LACQUER THINNER ON THEM!** Mark the inside of the speed cup at 0 before removing the old numbers with lacquer thinner. Sand the surfaces lightly with 220 aluminium oxide paper, lay the wheel on its side on the sandpaper, making a swipe or two over the paper, do both sides of the wheel. Put a wheel in tool #4. Wipe the sanded surfaces with isopropyl alcohol, after that do not touch the cleaned surfaces with your fingers.

With a razor blade make a small mark midway between each row of numbers, top and bottom. Line up a steel straight edge with the marks, and slice off each row of numbers. The decal for the speed cup (oval speedometer) can be trimmed with a straightedge and a razor blade, the decal for the speed cup of a round speedometer must be cut with scissors. Cut as smoothly as you can, little ragged edges cause the decal to tear very easily.

Soak a decal about one minute in lukewarm water, slide the decal off its backing and drape it over something, such as the end of your straightedge. Wrap the backing paper over the wheel to transfer some of the cement to the wheel. Now apply the decal on the wheel, aligning the bottom of the 2 with the pencil mark on the wooden dowel, or the mark on the side of the wheel, if you are doing it that way. The #9 end of the decal must overlap the 0 end. Centre the decal left to right on the wheel. Roll the wheel very gently between your fingers, be careful not to move the decal. With a slicing motion of a razor blade, trim the edges while the decals are still wet. Set the wheel aside to dry, a few hours at least. Handle the wheels gently, the decals are much more delicate than the original painted wheels. Follow the same procedures for the speed cup. When sliding curved decals off their backing paper, always slide them toward the inside to lessen the danger of tearing them. I like to have an extra set of decals on hand in case I ruin one. That does happen quite frequently.

Indenting, or upsetting, a spot on the number wheel shafts can be done easily, as shown in figure 15 below. Do not tighten the vise tight enough to actually squeeze the assembly, it should just hold the assembly solid, while you upset a spot on the shaft. I also put a drop of Loctite on the upsets, just to be sure. A 3/16" (or larger) lathe bit, ground as shown, allows you to strike straight down, rather than a little sideways as you will if you try to use a regular chisel.

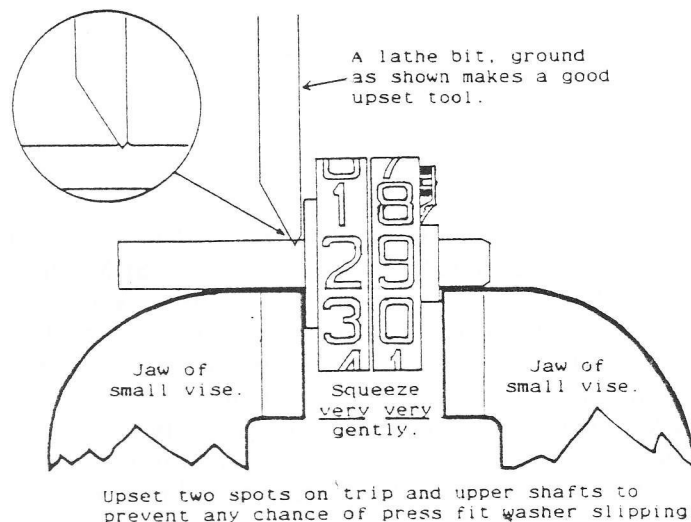

Figure 15

I glass bead the face. A coat of primer goes on next, followed by a coat of Krylon #1602 ultra flat black. Let it dry at least 24 hours. If your fingers touch it, they will leave a mark, so handle it by the edges.

Mark a sheet of paper as shown in fig 16-A. Set compass to draw a 7/8" circle, draw the outer arcs, reduce the radius and draw one or two more arcs.

Lay the face plate on the sheet of paper, use the arcs to centre the speed cup window (fig 16-B). Be very careful not to let the face plate move, as you tape it to the paper with scotch tape. Fold the paper forward, trimming it to leave an opening about 3/4" high x 1" wide. This keeps your fingers off the paint, and provides an exact centre in the window.

Figure 16-C. Cut a piece of scotch tape to the shape of ST 1, draw the curve on the scotch tape by tracing a number wheel. Install the tape in the position shown. Repeat with ST 2 followed by ST 3 to finish masking out the pointer. Use the eraser from a pencil to roll the edges of the tape down tightly. I use Liquid Paper correction fluid to paint the white pointer. A bright red acrylic enamel, or finger nail polish, can be used for a red pointer.

After making any necessary repairs to the case, install the inner works and tighten the retaining screw. Install the lead wire seal, pushing the wire into the enlarged hole, Do not flatten the lead, you may want to disassemble the unit again sometime. Install 2 lens gaskets, a clean lens, and the lens retainer into the bezel. Lay the face plate in place, making sure the notches are on the three lugs A. Make a new felt washer to fit tightly over the trip set shaft.

Install the bezel, squeezing it down evenly into place.

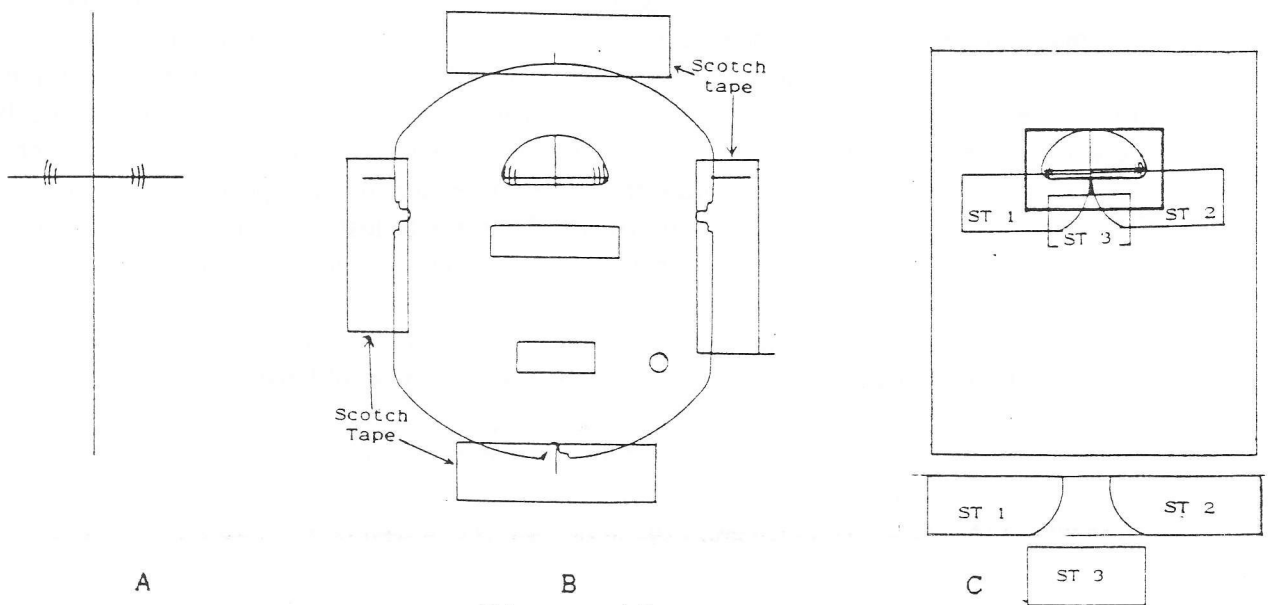

Figure 16

Page Twelve

THE FIRST



Motor Mail Van

... was a Daimler Motor Van supplied to the Post Office for trial by the British Motor Syndicate Ltd. A service began operating between St Martin's-le-Grand and the South Western District Post Office, Howick Place, a distance of 2-3/4 miles, during the week ending 23 October, 1897. A load of up to 900lb of letter mail was carried and the journey performed in both directions five times a day. A time of 23 minutes was allowed for the distance, the same as for horse-drawn vans but, according to contemporary reports, the motor van 'not only kept better time than they usually do, but as a rule reached the destination at each end before it was due'. The motor van was also used for carrying parcels between Howick Place and Kingston-upon-Thames the following week, making the 30-mile round journey in 5hrs, including six stops for deliveries and a 1/2hr break at Kingston.

The first regular service commenced on 17 June, 1898, when a Daimler Wagonette supplied by the West of Scotland Motor Co began running between Inverary and Ardrishaig, Argyllshire, a distance of 26-1/2 miles, which it performed in about 3hrs at an average speed of 8-1/2mph. The service continued until bad roads and mechanical failures during the winter led to a reversion to horse-working. BS •

Notebook

BIRTHDAYS for AUGUST: Birthstone: Peridot; Flower: Gladiolus

Michael Bell, Coral Blewett, Pat Bussard, Alec Christie, Colin Davidson, Gwen Guest, Ken Harris, Ross Letch, Helen Moorehead & Bill Swinbank. Many happy returns!

CHANGE OF ADDRESS: Lindsay Blacklock has moved to [REDACTED] Madora, WA 6210. Chris & Leanne Wringe are now at [REDACTED] Dianella, WA 6062. Ph: [REDACTED] Please alter your member directory.

CHRISTMAS IN JULY: We enjoyed a great evening, thank you Dora. A full report of the event is in this newsletter.

CHRISTMAS LUNCH - thanks to Pat Laurie, who has booked us into the Peppermill Restaurant in Gidgegannup. All the details are in the 'Calendar'.

TO THE OWNER of a brown folda chair left at the Reads on Sunday, 26th July. Please claim your property.

FOR SALE:

'29 Roadster - dismantled. Mechanically ready to assemble.
Fully reconditioned, motor running
Price: \$6000 also new parts \$200 ono.
Phone: Chris Marti on [REDACTED]

Manifold Cooking Trays - \$20
Available from Darren Jeffree Ph [REDACTED]

AROUND AUSTRALIA TRAVELLERS have been and gone. From all reports they enjoyed our hospitality. John & Shirley Hall dined with them on the Friday night after they arrived and other club members caught up with them on Sunday. A bus was hired for the occasion and Steve Read was the coach captain for the day, showing our visitors the sights of Perth and Fremantle. Shirley played hostess for the occasion-- supplying afternoon tea at the Hall residence on the return journey to Caversham. We hope they enjoyed their brief visit and have a safe journey home.

SURVIVAL OF THE FITTEST: *The following was sent in by Colin Strahan, believed to be 'borrowed' from another source.*

Every day some new do-gooder is trying to save us from ourselves. We have so many laws and safety commissions, committees, groups and teams to ensure our safety, it seems nearly impossible to have an accident.

The problem is that we need accidents and lots of them.

Danger is nature's way of eliminating stupid people. With safety, however well intentioned, we are developing into half-witted mutants because idiots, who by all rights should be dead, are spared from their rightful early graves and are free to breed more imbeciles.

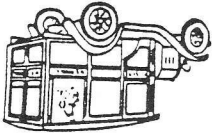

BALDIVIS WA 6171
BUSSARD David & Pat



If undelivered, please return to:
Thornlie
Western Australia, 6108

Western Model A News

~ OFFICE BEARERS FOR 1998/99 ~

President

David Bussard

BALDIVIS WA 6171
Phone [REDACTED]

Vice President

Peter Sartori

MURDOCH WA 6150
Phone [REDACTED]

Secretary/Treasurer

Pat Bussard

BALDIVIS WA 6171
Phone [REDACTED]

Editor

Louise Read

THORNIE WA 6108
Phone [REDACTED]

Committee Members

Alan Smith

MARMION WA 6020
Phone [REDACTED]

John Moorehead

LEEMING WA 6149
Phone [REDACTED]

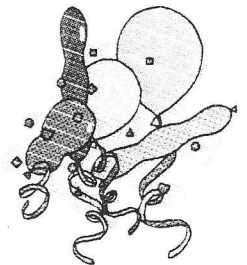
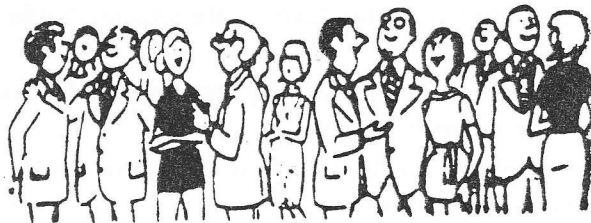
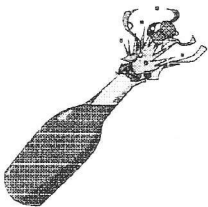

RAY ABBOTT ENGINE RECONDITIONING

** Specialising in Veteran and Vintage engines*

** Cylinder Head Service * Reboring and Sleeving * Crankshaft Grinding*

Recommended by MARC member

Established 1973

18 RIO STREET, BAYSWATER

9272 4566

34 years Experience